

Power Management in Renewable Energy Microgrids with Hybrid Storage

Carlos Bordons

*Systems Engineering and Automaticon Dpt.
University of Seville, Spain*



Centre of Research Excellence
for Advanced Cooperative Systems

- Power Management in micro-grids with **renewable sources** (wind and solar) and hybrid (**hydrogen and electricity**) storage
- Focus on the control methodology: open issue
- Model predictive control
- Implementation on a laboratory plant
- Assessment by KPI
- Control objectives: power balance, durability, economic profit, etc.

1. Setting the Context

2. Microgrids
3. Experimental testing facility: HyLab
4. Model Predictive Control for μ Grid Power Management
5. Extended control objectives
6. Concluding remarks

The demand for energy, especially for electricity, has increased exponentially for years

Figure 1. World energy consumption, 1990-2040
quadrillion Btu

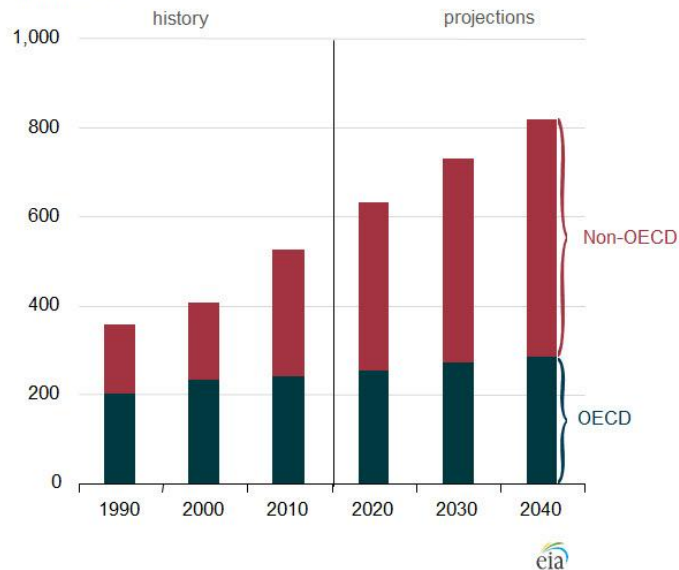

Source: U.S. Energy Information Agency

We need more energy and it needs to be cleaner → Renewable Energy sources can be a solution



■ Energy mandates

- ❑ USA → 20-33%
- ❑ EU's 20-20-20 → 20%

2020

■ Environmental regulations and security of supply

- Coal plants phase-out
- Nuclear phase-out (Germany, Italy, Japan, Switzerland, Austria, Sweden. .etc.)

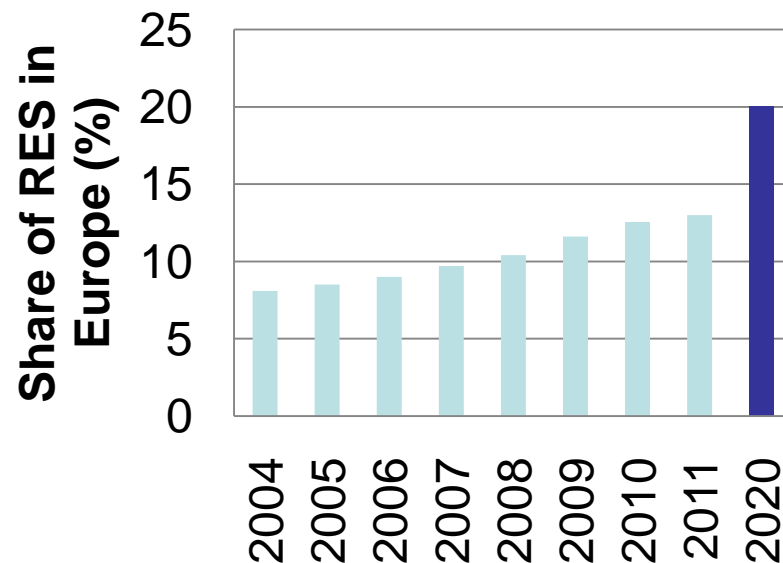

Source: Eurostat

Wind and solar energy

Wind power installed in Croatia

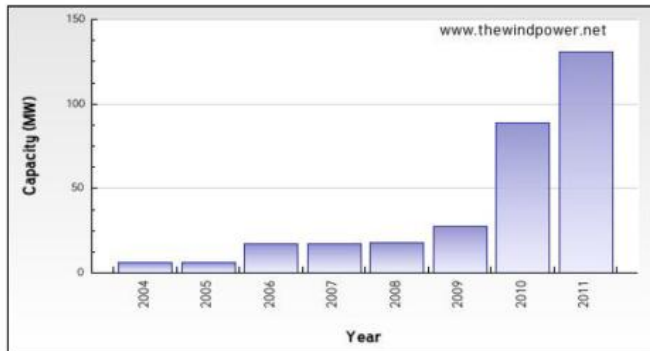

Source: http://www.thewindpower.net/country_en_45_croatia.php

MailOnline



Home News U.S. | Sport | TV&Showbiz | Femail | Health | Science | Money | Video

News Home | Arts | Headlines | Pictures | Most read | News Board

Wind farms paid £30 million a year to stand idle because the grid can't cope with all the energy they produce

- Wind farms paid millions when National Grid is unable to use their energy
- Last weekend alone energy firms were paid £3.1million to switch off

By NICK McDERMOTT

PUBLISHED: 21:33 GMT, 9 August 2013 | UPDATED: 09:32 GMT, 25 September 2013

Structure of renewable energy sources to 2020 (with a view to 2030)

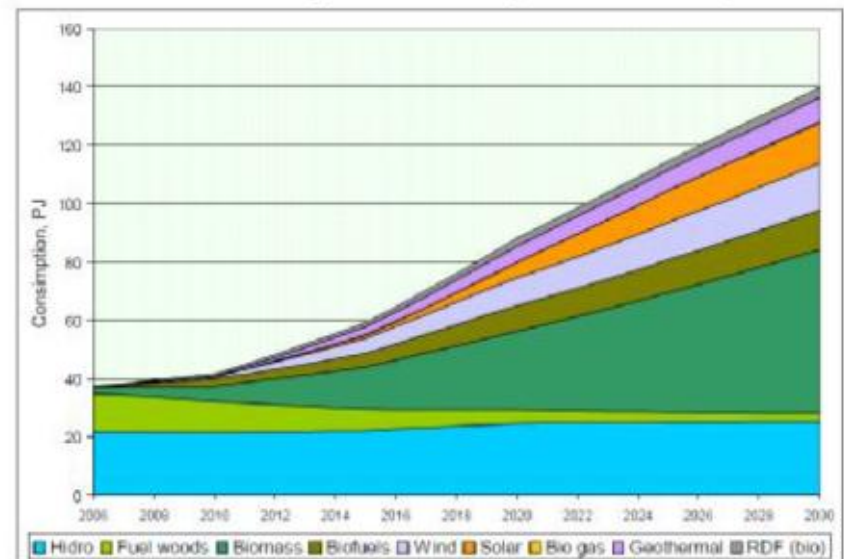

The New York Times

Business

THE ENERGY CHALLENGE

Wind Energy Bumps Into Power Grid's Limits

> Wind farms in Pacific Northwest paid to not produce

Oversupply of renewable power

Energy storage must become an integral element of the renewable adoption strategy

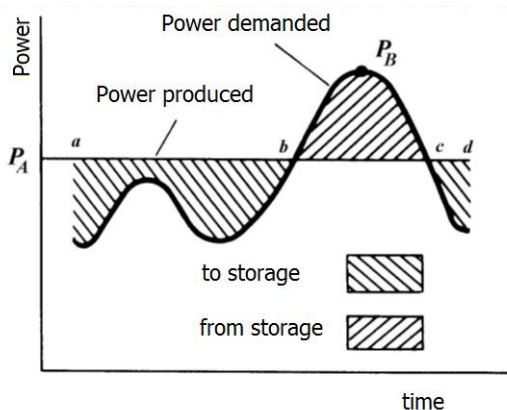

- Cover a range of time scales
- H2, batteries, ultracapacitor, flying wheels, etc.
- Different dynamics-different term. Complementary

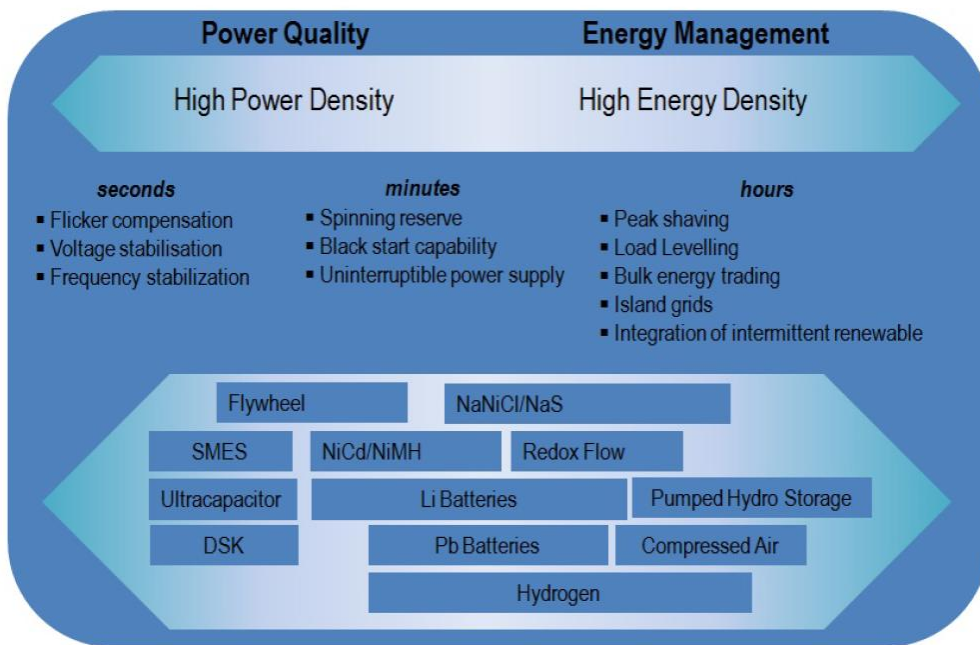

Storage allows a non-dispatchable generator (RES) to be dispatchable

Storage must be operated in an optimal way

Hydrogen can be an option: **high energy density** and **high power density**

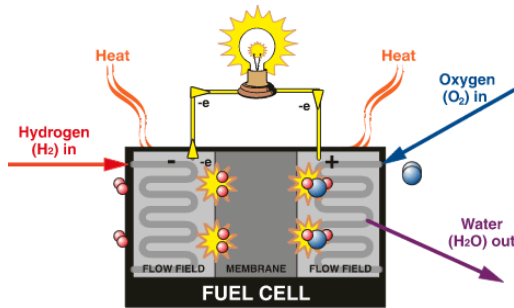

Also for FCHVs:
Toyota FCV April 2015

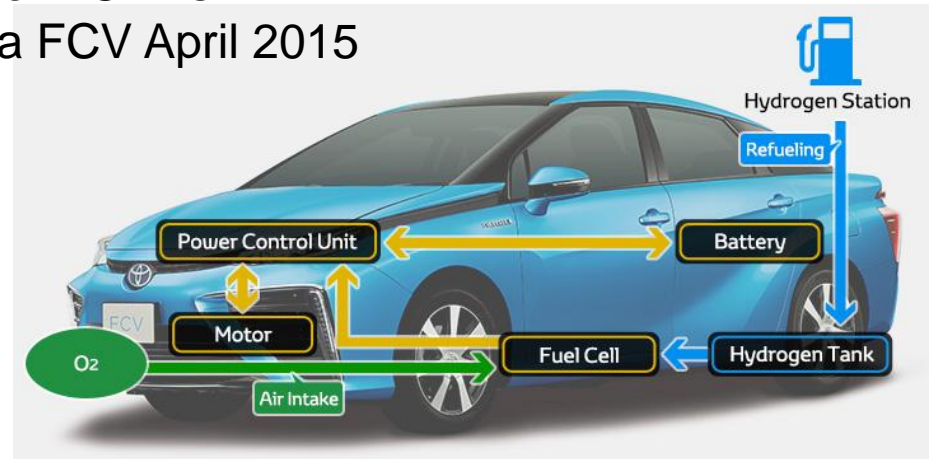

“The Green Hydrogen Cycle”

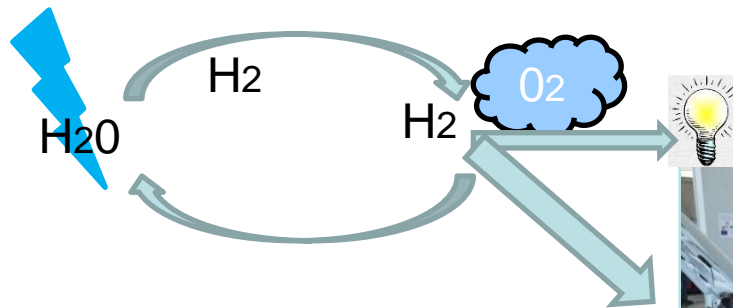

Hybrid storage in vehicles
(batteries + H₂ tanks)

Distributed and mobile storage

The importance of control strategies in RES-H2

Microgrid

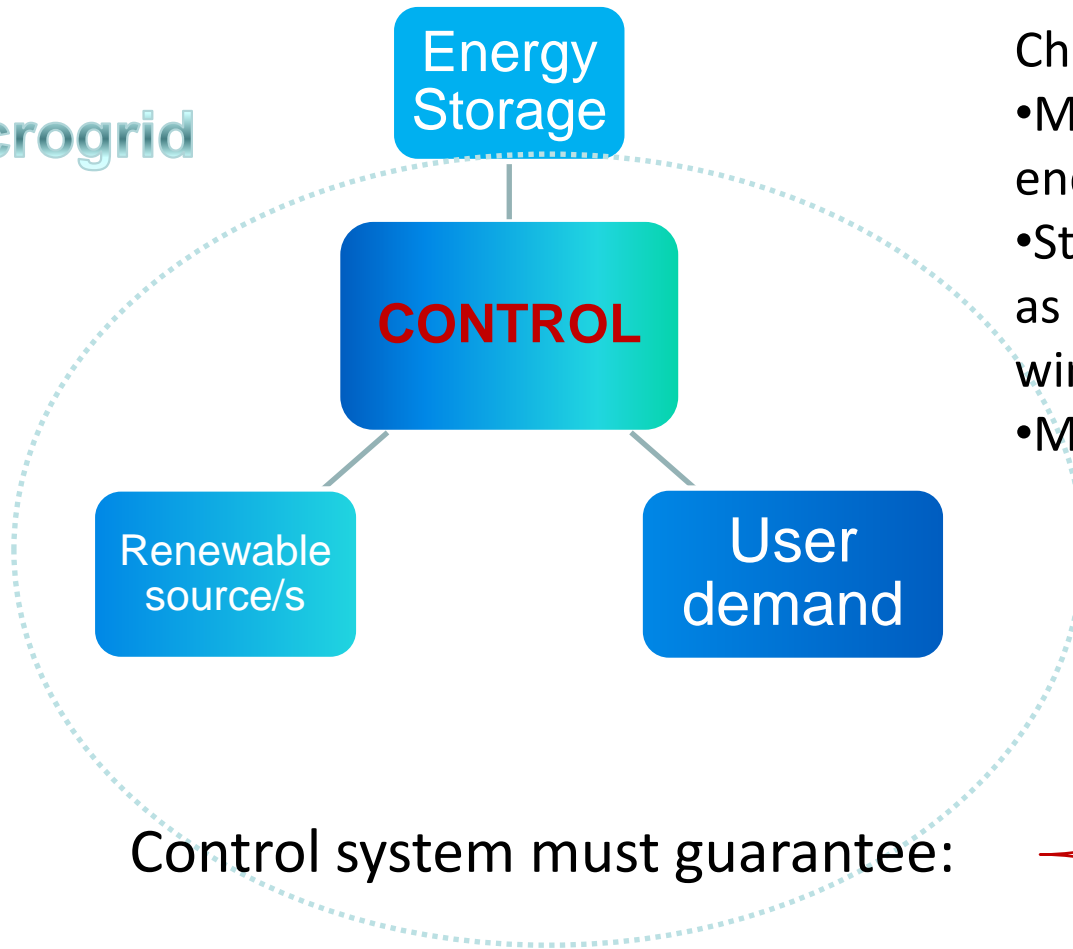

Control system must guarantee:

Challenges:

- Maintain energy security for end-users
- Stabilize the electrical grid so as to avoid disconnections of wind farms and solar fields
- Make RES dispatchable

- Efficiency
- Lifetime
- Economic
- Safety

1. Setting the Context

2. Microgrids

3. Experimental testing facility: HyLab

4. Model Predictive Control for μ Grid Power Management

5. Extended control objectives

6. Concluding remarks

- Portion of an electric power distribution system that includes a variety of **DER** units and different types of **end users** of **electricity and/or heat**.
- DER (Distributed Energy Resource) units:
 - Distributed generation (DG)
 - Distributed storage (DS) .
- It can work in Islanded/grid-connected mode
- AC or **DC** microgrid

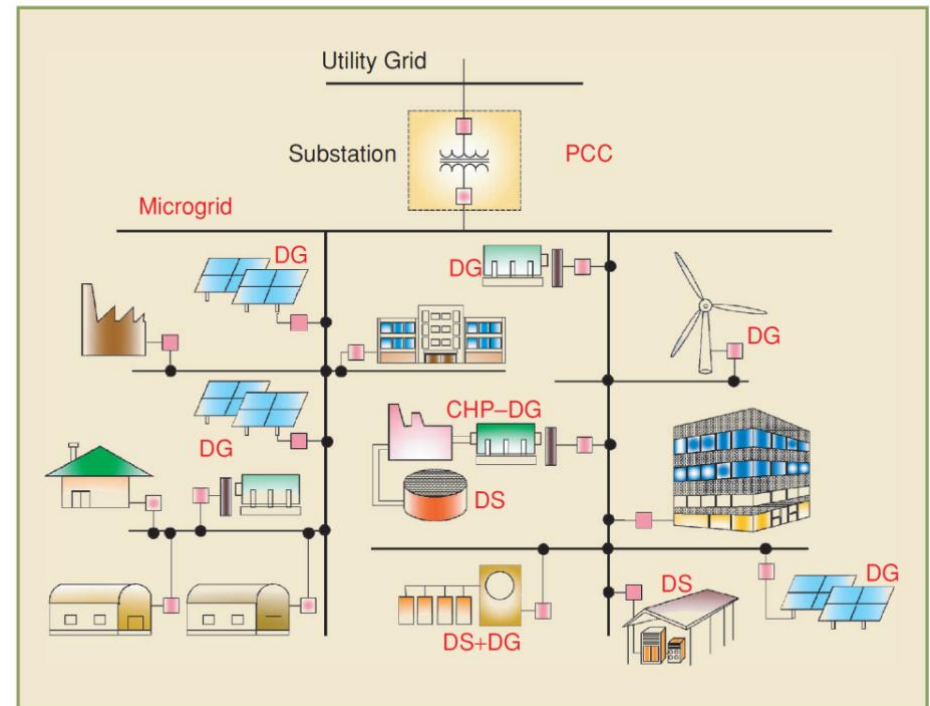

- Supply and demand **balancing**
- Power **quality**: avoid variations as harmonic distortion or sudden events as interruptions or even voltage dips.
- In isolated mode: **Voltage** and **frequency** management
- Economic benefit
- **This talk focuses on DC microgrids**

Manipulated the dispatchable units in the proper way

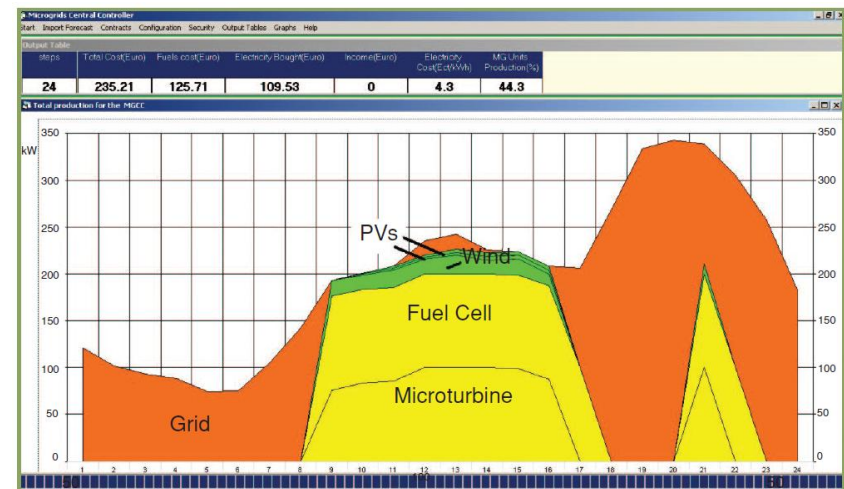
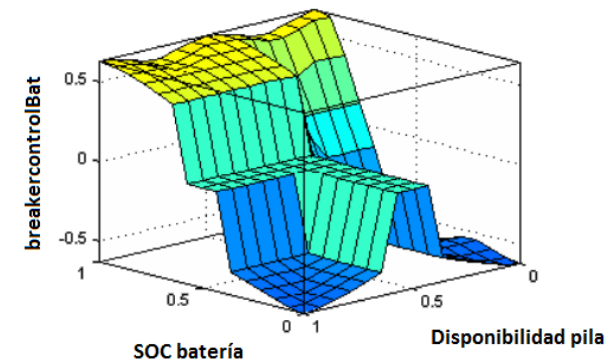

figure 14. Display of DER dispatch and energy imported from the grid.

400 kW Microgrid

In the last ten years, experience has demonstrated that **system performance is highly subject to the control strategy**

- ❑ HYSTERESIS BAND CONTROL (Ulleberg, 2003), (Ghosh, 2003), (Ipsakis, 2008)
- ❑ NEURAL NETWORK (López, 2007)
- ❑ FUZZY LOGIC (Bilodeau, 2006), (Stewart, 2009) (Hajizadeh , 2009)
- ❑ DROOP CONTROL (Vasak, 2014)
- ❑ MODEL PREDICTIVE CONTROL (Del Real, 2007) (Baotic, 2014)



Challenges translated into innovative control strategies that **can benefit efficiency and cost reduction** to make this technology more competitive.

Hysteresis band technique

The whole operation is based on the battery's state of charge (SOC)

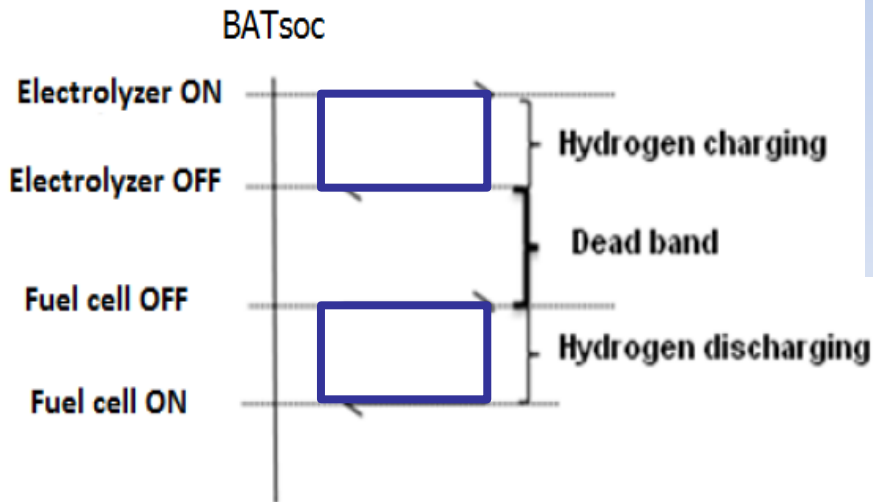

Very simple and reliable

Non optimal
Low efficiency
Equipment degradation

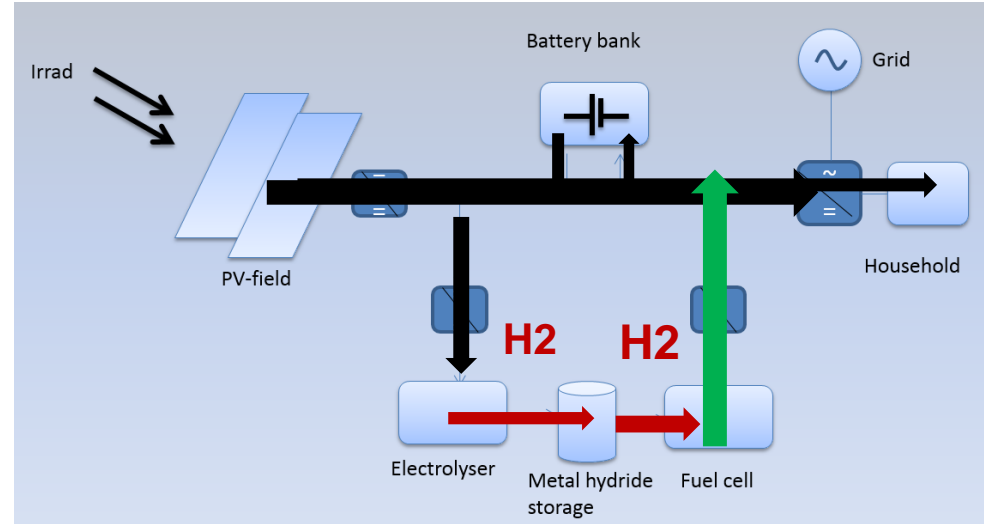

PV: non-dispatchable
FC: dispatchable

- Is heuristic control the cause of premature **degradation**?
- Which are the different ways of operating the equipment in a μ G? What are the best ways? Can we quantify the **goodness** of a control strategy?
- Why **optimal** control has not been developed and demonstrated in hydrogen μ Gs? Can it provide solutions?
- What are the steps towards the **development and validation** of an optimal controller?
- What are the greatest technical **challenges** facing H₂-microgrids optimal control?



- The use of MPC technique allows to **maximize** the economical benefit of the microgrid, **minimizing** the degradation causes of each storage system, fulfilling the different system constraints.
- MPC can be used for
 - Dispatch/Schedule
 - Power quality/service

Optimization over a future receding horizon using a dynamic model of the plant

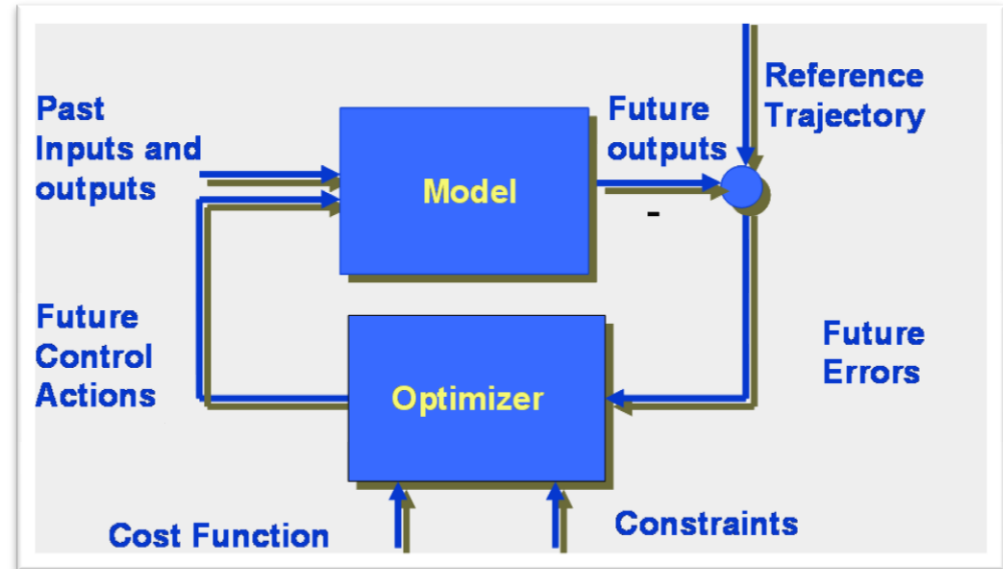

1. Setting the Context

2. Microgrids

3. Experimental testing facility: HyLab

4. Model Predictive Control for μ Grid Power Management

5. Extended control objectives

6. Concluding remarks

HYLAB (Hydrogen and control research Lab)

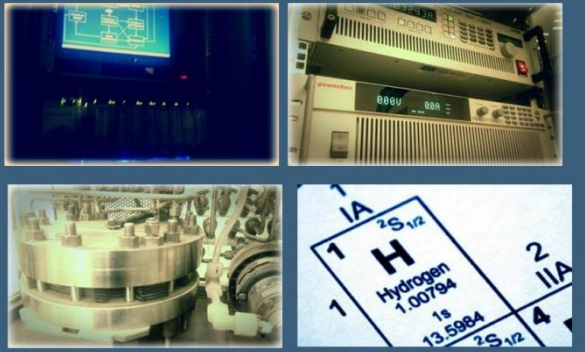

<https://sites.google.com/site/laboratorioh2/>



DC microgrid

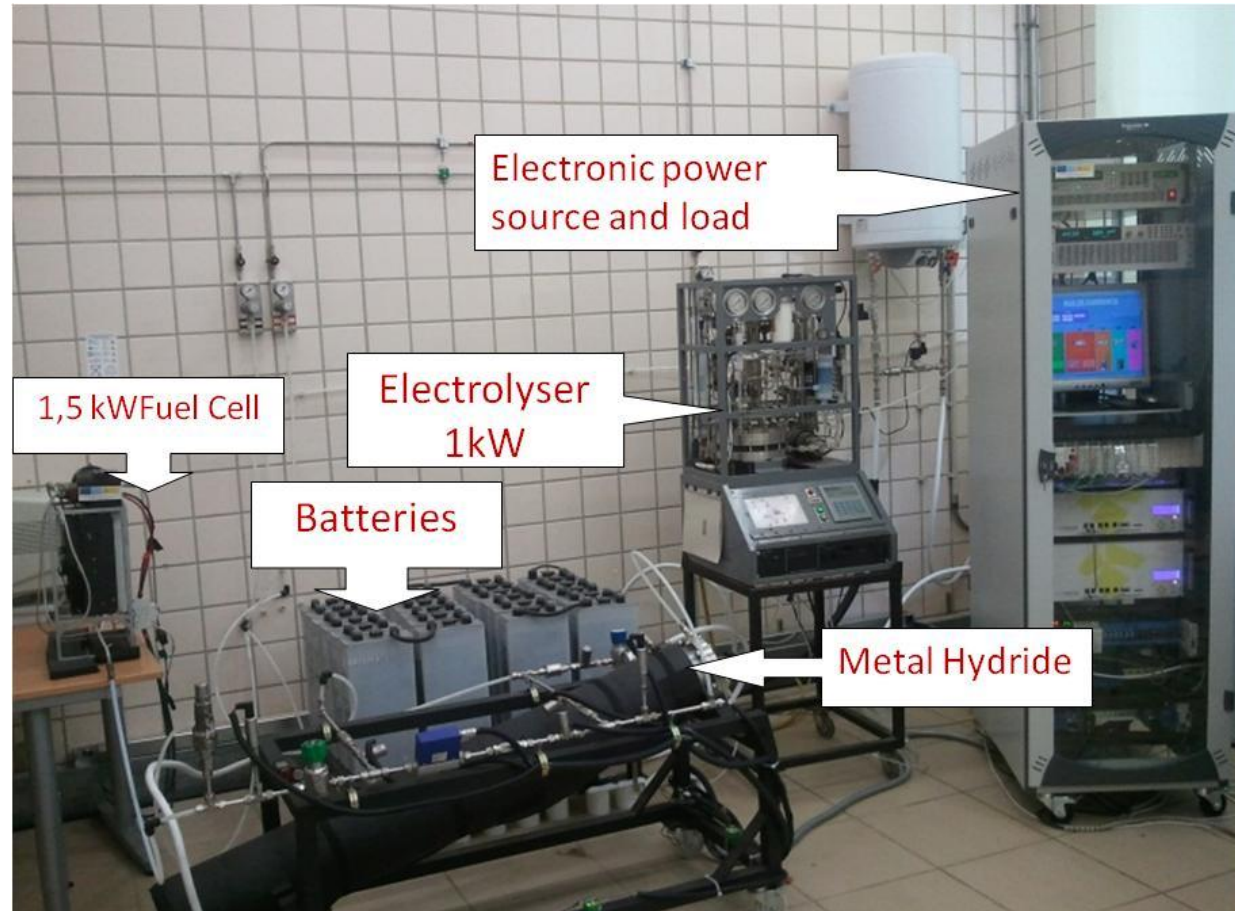

Wind- hydrogen

Project name	Year	Country
HARI	2004	UK
UTSIRA	2004	NORWAY
ITHER	2005	SPAIN
RES2H2	2005	GREECE
PURE	2005	UK
SOTAVENTO	2007	SPAIN
RES2H2	2007	SPAIN
PEIP	2008	CANADA
HIDROLICA	2009	SPAIN
R. Island P.	2010	CANADA
HYDROGEN OFFICE	2010	UK

PV- hydrogen

Project name	Year	Country
FIRST	2002	SPAIN
HARI	2002	U.K
HRI	2001	CANADA
INTA	1997	SPAIN
PHOEBUS	1993	GERMANY
SAPHYS	1994	ITALY
SCHATZ	1989	USA
Solar house	1992	ITALY
Solar hydrogen pilot	1990	FINLAND
SWB	1989	GERMANY
CEC	2007	USA
LARES	2014	CROATIA

- Percentage of Non-Satisfied Demand (%NSD)
- Fuel Cell and Electrolyser number of start-stop events (START-STOP)
- Percentage of Unused eNErgy from renewables (%UNE)
- Metal Hydride hydrogen storage Level (MHL)
- Batteries State Of Charge (SOC)
- Fuel Cell and Electrolyser running time (t_{fc}, t_{ez})
- Hydrogen produced/consumed ratio (r_{H2})
- Fuel Cell and electrolyser operating constraints trespassing event (e-Alarm)
- Fuel Cell and Electrolyser average efficiency (η_{ez}, η_{fc})
- Efficiency of energy path (η_{path})
- Plant operating cost (O&MC)

Luis Valverde. “Energy management in systems with renewable sources and energy storage based on hydrogen using model predictive control”, PhD Thesis, University of Seville, 2013

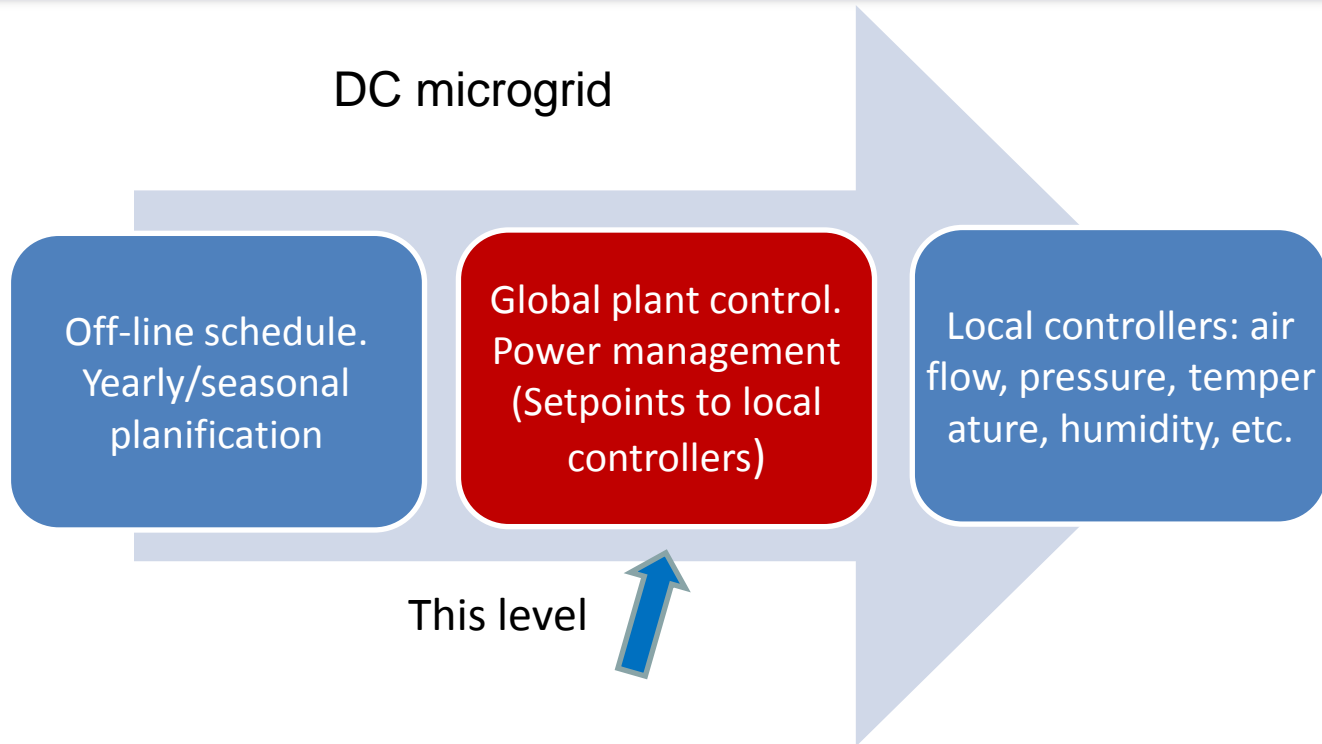

Since the generated (renewable) power does not fit the demanded load, the controller must compute the setpoints to the local controllers of FC, ELZ and grid **in order to balance the power**

Try to optimize some KPIs

1. Setting the Context
2. Microgrids
3. Experimental testing facility: HyLab
- 4. Model Predictive Control for μ Grid Power Management**
5. Extended control objectives
6. Concluding remarks

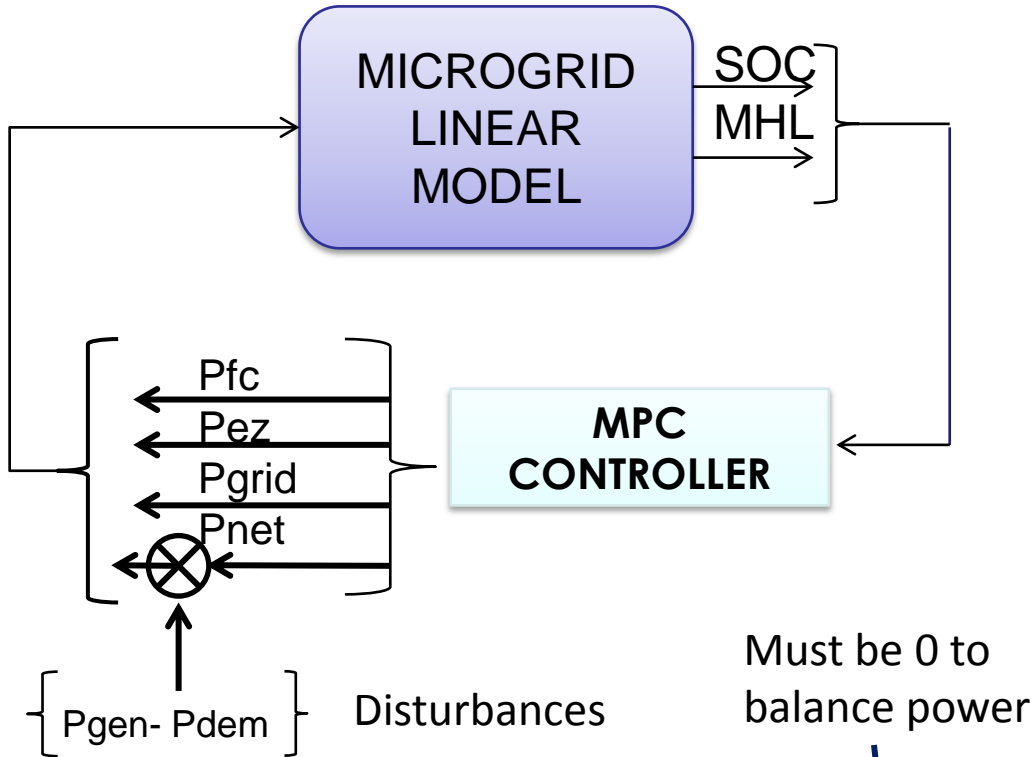

Power in the battery bank:

$$P_{bat} = P_{gen} - P_{dem} + P_{fc} - P_{ez} + P_{grid} + P_{net}$$

Must be 0 to balance power

MPC Inputs (CVs):
 Battery SOC
 Metal Hydride Level

MPC:
 Constraints
 Cost function minimization

MPC outputs (MVs):
 FC Power
 ELZ Power
 Grid Power
 Net Power (slack)

The behavior of the MPC is defined by the **cost function**

(Objective)

3 weighted objectives

- Power balance
- Keep storage levels (H2 and electricity)
- Protect equipment from intensive use

The first group of weighting factors controls which equipment is used first

$$J = \sum_{k=1}^{Nu} \alpha_1 P_{fc(t+k)}^2 + \alpha_2 P_{ez(t+k)}^2 + \alpha_3 P_{grid(t+k)}^2 + \alpha_4 P_{net(t+k)}^2 +$$
$$+ \beta_1 \Delta P_{fc(t+k)}^2 + \beta_2 \Delta P_{ez(t+k)}^2 + \beta_3 \Delta P_{grid(t+k)}^2 + \beta_4 \Delta P_{net(t+k)}^2 +$$
$$+ \sum_{k=1}^N \gamma_1 SOC_{(t+k)} - SOC_{ref}^2 + \gamma_2 MHL_{(t+k)} - MHL_{ref}^2$$

The second group (β) is set to protect the equipment from intensive use

The γ group penalizes the error in reference tracking in order to give flexibility to the plant operation

Different set of parameters for different objectives
(or operating conditions: sunny, cloudy, etc.)

Controller constraints and implementation

Constraints: power and power rates limits. Storage limits

$$P_{ez,min} = 100W \leq P_{ez} \leq 900W = P_{ez,max}$$

$$P_{fc,min} = 100W \leq P_{fc} \leq 900W = P_{fc,max}$$

$$P_{grid,min} = -2500kW \leq P_{grid} \leq 6kW = P_{grid,max}$$

$$P_{net,min} = -2500 W \leq P_{net} \leq 6 kW = P_{net,max}$$

$$\Delta P_{fc,min} = -20 W/s \leq \Delta P_{fc} \leq 20 W/s = \Delta P_{fc,max}$$

$$\Delta P_{fc,min} = -20 W/s \leq \Delta P_{fc} \leq 20 W/s = \Delta P_{fc,max}$$

$$\Delta P_{net,min} = -2500 W/s \leq \Delta P_{net} \leq 6000 W/s = \Delta P_{net,max}$$

$$\Delta P_{grid,min} = -1000 W/s \leq \Delta P_{grid} \leq 1000 W/s = \Delta P_{grid,max}$$

$$SOC_{min} = 40 \% \leq SOC \leq 75 \% = SOC_{max}$$

$$MHL_{min} = 10 \% \leq MHL \leq 90 \% = MHL_{max}$$

Implementation

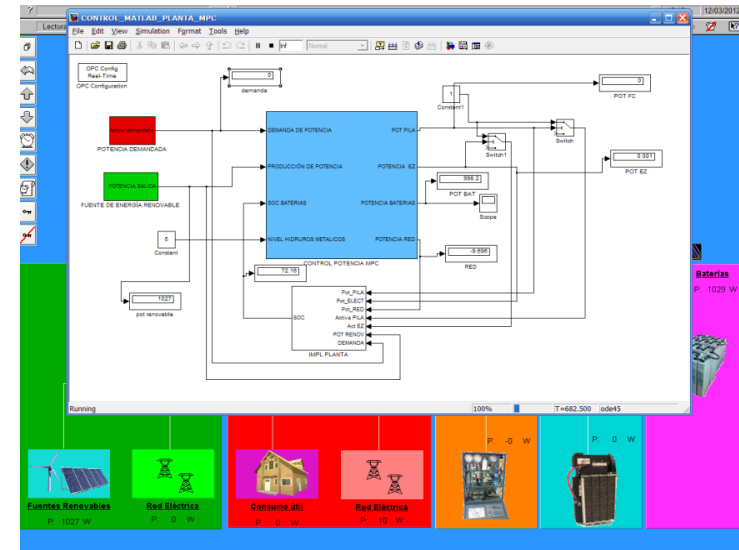

Matlab/Simulink → PLC
Real-Time control

Quadratic
Programming

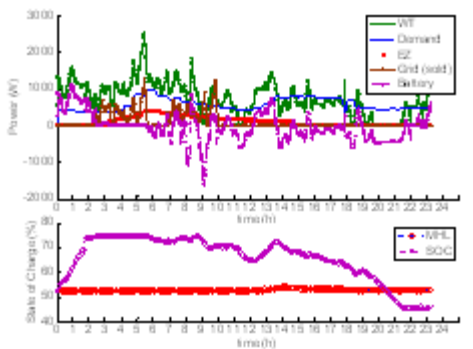
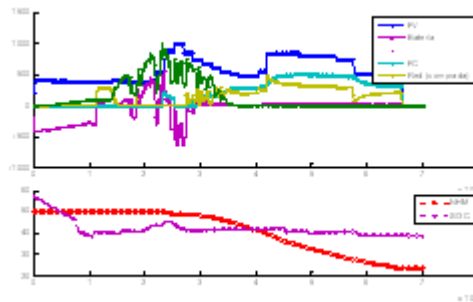
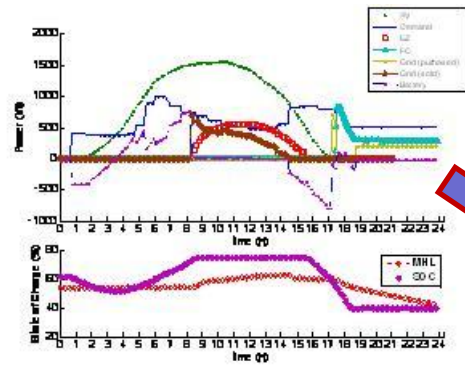

Sunny day

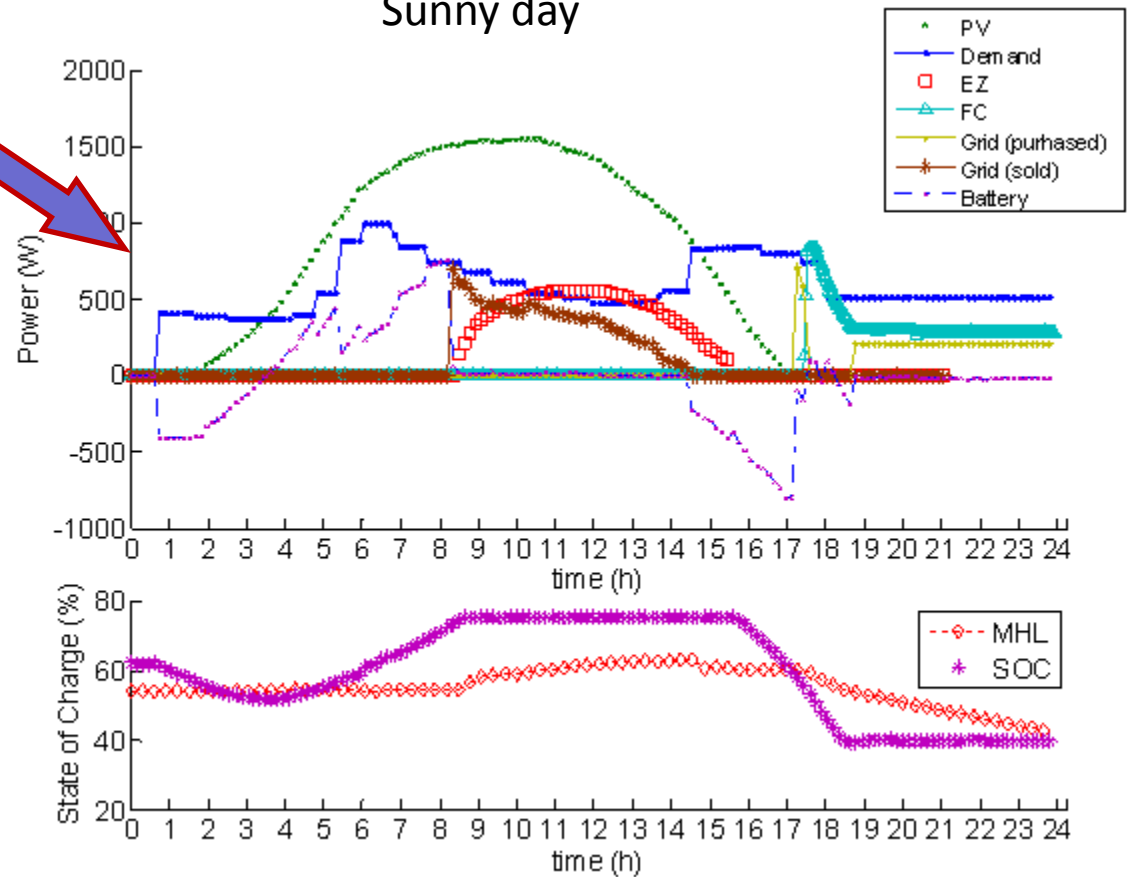

The weights can be changed to fulfill other objectives or change priorities

- SOC tracking
- Setpoint at 40%
- The power developed by other unit changes accordingly
- Solved by a centralized QP

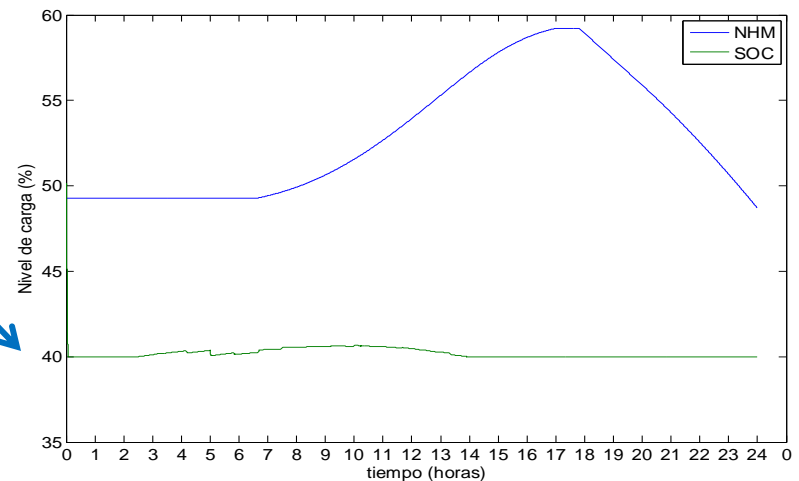
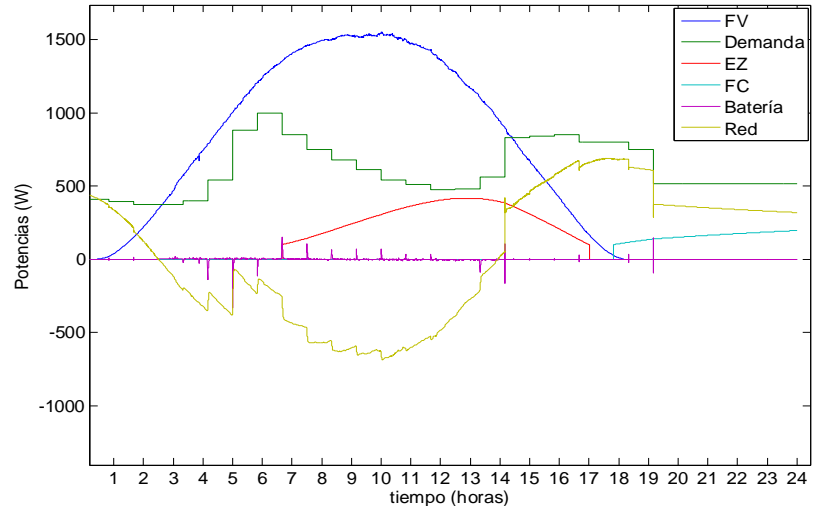

Comparison with traditional control

MPC	Heuristic control
Fewer start-up/shut down (25% fewer) START-STOP	Uncontrolled start-up/shut downs
Variable power → More energy stored (+5% MHL)	Variable power → more energy but equipment damage (intensive use) Fixed power → low efficiency
Smooth power references η_{ez} , η_{fc}	Directly absorbs wind/solar fluctuations
Higher equipment efficiency (low currents) η_{path}	Low equipment efficiency (unless specific operating mode)
Lower operational cost (-30%) O&MC	Higher cost

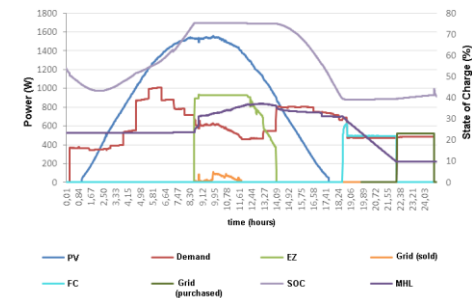
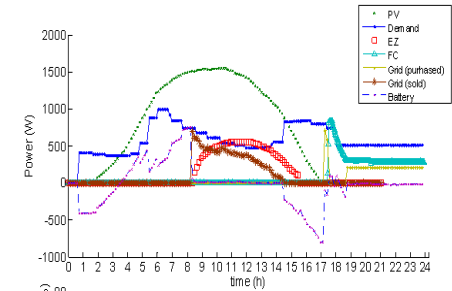

1. Setting the Context
2. Microgrids
3. Experimental testing facility: HyLab
4. Model Predictive Control for μ Grid Power Management
- 5. Extended control objectives**
6. Concluding remarks

Durability, O&M costs, optimal schedule

- Reformulate the MPC problem
- Durability is an important issue in ESS

Durability: Full Load On/Off Cycling 5,400 on/off cycles demonstrated

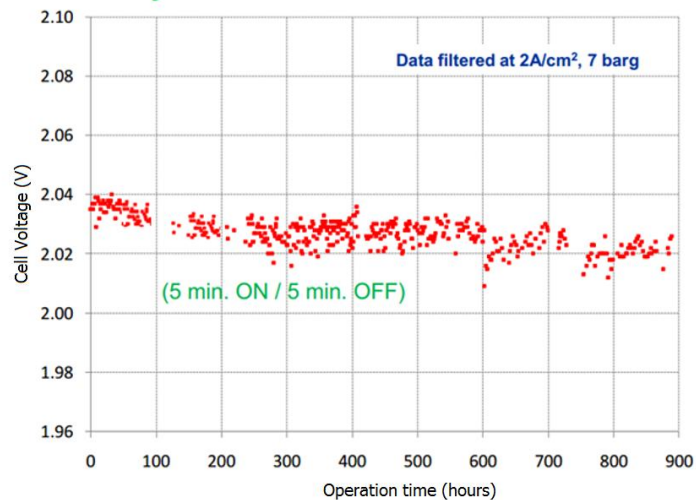

Metal hydride storage

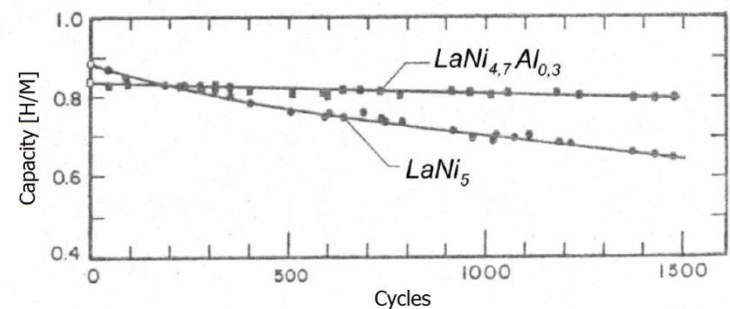

- Batteries: Manufacturers of batteries quantify the life of this ESS as a function of the number of the charge and discharge cycles.
- Ultracapacitor: similar.

$$\begin{aligned}
 J_{bat} = & \sum_{h_i=1}^{24} \left(\frac{CC_{bat}}{2 \cdot Cycles_{bat}} P_{bat,ch}(h_i) \cdot T_s \cdot \eta_{bat,ch} \right. \\
 & + Cost_{degr,ch} \cdot P_{bat,ch}^2(h_i) \\
 & + \frac{CC_{bat}}{2 \cdot Cycles_{bat}} \frac{P_{bat,dis}(h_i) \cdot T_s}{\eta_{dis,bat}} \\
 & \left. + Cost_{degr,dis} \cdot P_{bat,dis}^2(h_i) \right)
 \end{aligned}$$

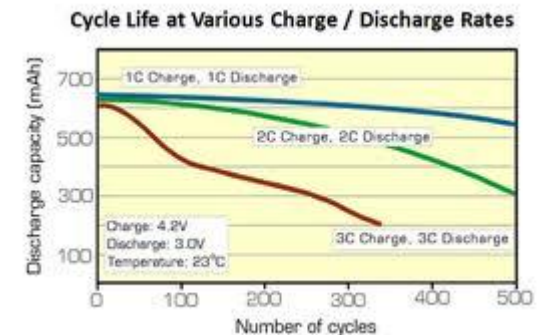

- Manufacturers of electrolyzers and fuel cells give the life expression of this kind of systems as a function of the number of working life. **Start up and shut down cycles** and **fluctuating load** conditions can affect seriously to these devices.
- Logical variables included: on/off states (δ) startup and shutdown states (σ)

$$\sigma_j^{on}(t_k) = \max(\delta_j(t_k) - \delta_j(t_{k-1}), 0) |_{j=elz,fc}$$

$$\sigma_j^{off}(t_k) = \max(\delta_j(t_{k-1}) - \delta_j(t_k), 0) |_{j=elz,fc}$$

$$J_{elz}(h_i) = \left(\frac{CC_{elz}}{Hours_{elz}} + Cost_{o\&m,elz} \right) \delta_{elz}(h_i) +$$

$$Cost_{startup,elz} \cdot \sigma_{elz}^{on}(h_i) + Cost_{shutdown,elz} \cdot \sigma_{elz}^{off}(h_i)$$

$$+ Cost_{degr,elz} \cdot \vartheta_{elz}^2(h_i)$$

$$J_{fc}(h_i) = \left(\frac{CC_{fc}}{Hours_{fc}} + Cost_{o\&m,fc} \right) \delta_{fc}(h_i) +$$

$$Cost_{startup,fc} \cdot \sigma_{fc}^{on}(h_i) + Cost_{shutdown,fc} \cdot \sigma_{fc}^{off}(h_i)$$

$$+ Cost_{degr,fc} \cdot \vartheta_{fc}^2(h_i)$$

- Microgrid at CNH2 (not at full operation yet)
- **Optimal scheduling policy** linked to the time-varying price of energy. The results show an optimal behaviour of the microgrid whose **non-dispatchable generation is converted into dispatchable using the ESS.**
- The microgrid operator can act as a conventional power plant (gas, coal, etc.) and participate in the auction process

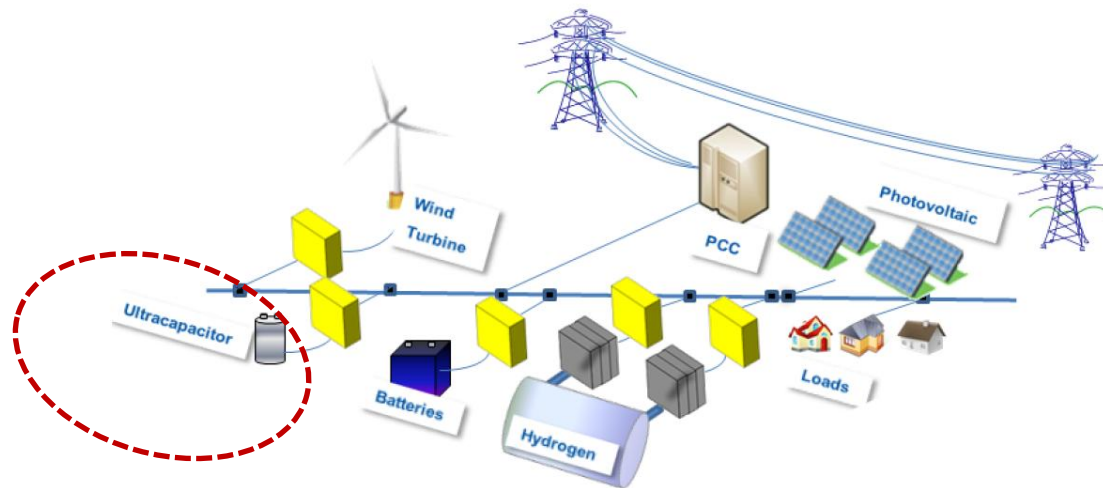

- The horizon schedule determines also the most appropriate ESS technology to be used.
- Durability included
- As well as the deviation schedule penalty with respect to the main grid
- Four level-cascaded MPC
- Forecast of available energy and electricity prices is included in the controller

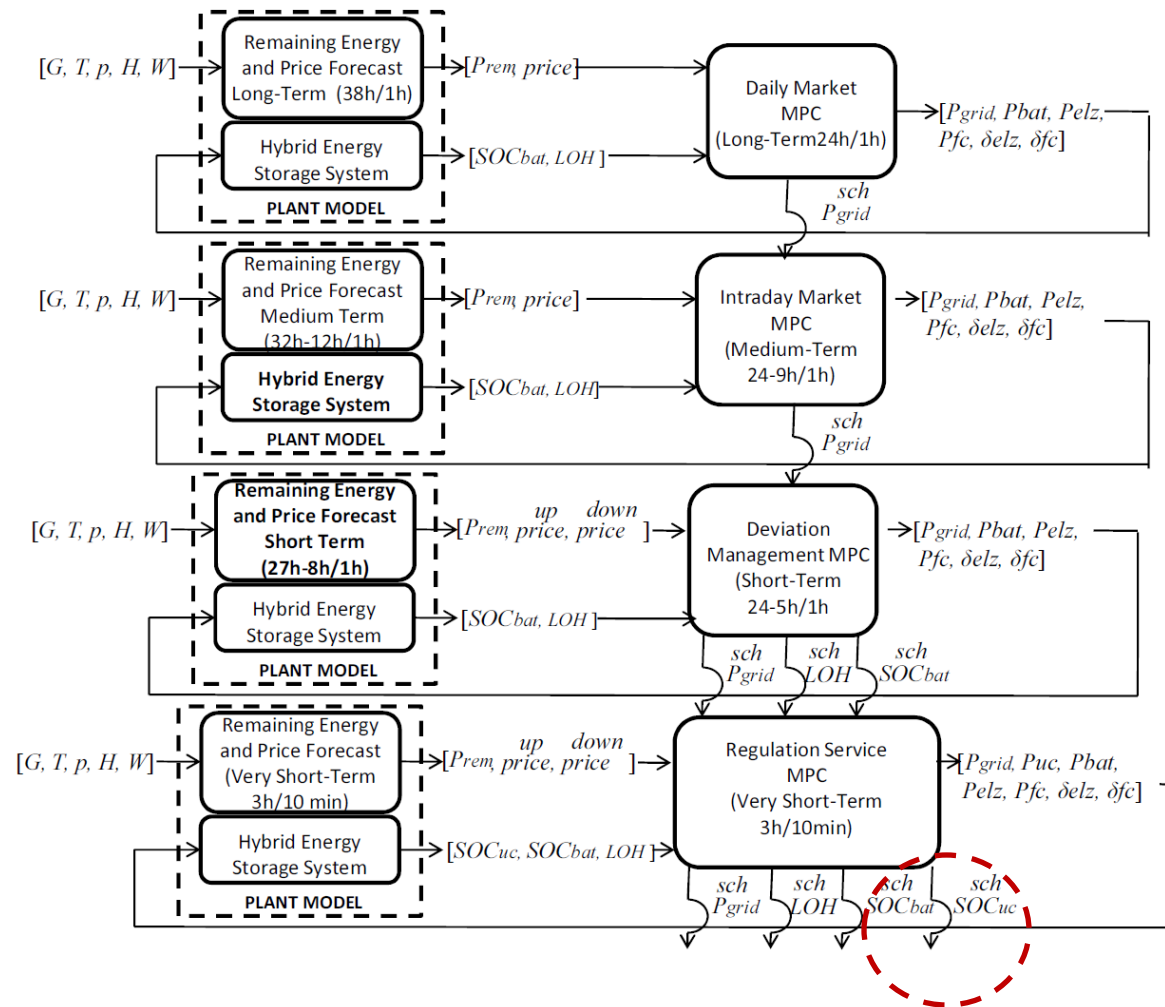

Logical constraints (example)

$$\begin{aligned}
 0 &\leq \delta_{sale}(t_k) + \delta_{pur}(t_k) \leq 1 \\
 P_{sale}(t_k) - P_{pur}(t_k) &= P_{grid}(t_k) \\
 P_{grid}^{min} \delta_{sale}(t_k) &\leq P_{sale}(t_k) \leq P_{grid}^{max} \delta_{sale}(t_k) \\
 P_{grid}(t_k) - P_{grid}^{max} (1 - \delta_{sale}(t_k)) &\leq P_{sale}(t_k) \\
 P_{sale}(t_k) &\leq P_{grid}(t_k) - P_{grid}^{min} (1 - \delta_{sale}(t_k)) \\
 0 &\leq \delta_{ch,i}(t_k) + \delta_{dis,i}(t_k) \leq 1 |_{i=uc,bat} \\
 P_{ch,i}(t_k) - P_{dis,i}(t_k) &= P_i(t_k) |_{i=uc,bat} \\
 P_i^{min} \delta_{ch,i}(t_k) &\leq P_{ch,i}(t_k) \leq P_i^{max} \delta_{ch,i}(t_k) |_{i=uc,bat} \\
 P_i(t_k) - P_i^{max} (1 - \delta_{ch,i}(t_k)) &\leq P_{ch,i}(t_k) |_{i=uc,bat} \\
 P_{ch,i}(t_k) &\leq P_i(t_k) - P_i^{min} (1 - \delta_{ch,i}(t_k)) |_{i=uc,bat} \\
 0 &\leq \delta_{elz}(t_k) + \delta_{fc}(t_k) \leq 1 \\
 -\delta_i(t_k) + \sigma_i^{on}(t_k) &\leq 0 |_{i=elz,fc} \\
 -(1 - \delta_i(t_k - 1)) + \sigma_i^{on}(t_k) &\leq 0 |_{i=elz,fc} \\
 \delta_i(t_k) + (1 - \delta_i(t_k - 1)) - \sigma_i^{on}(t_k) &\leq 1 |_{i=elz,fc} \\
 -\delta_i(t_k - 1) + \sigma_i^{off}(t_k) &\leq 0 |_{i=elz,fc} \\
 -(1 - \delta_i(t_k)) + \sigma_i^{off}(t_k) &\leq 0 |_{i=elz,fc} \\
 \delta_i(t_k - 1) + (1 - \delta_i(t_k)) - \sigma_i^{off}(t_k) &\leq 1 |_{i=elz,fc}
 \end{aligned}$$

$$\begin{aligned}
 P_i^{min} \delta_i(t_k) &\leq z_i(t_k) \leq P_i^{max} \delta_i(t_k) |_{i=pur,sale,elz,fc}^{up,down} \\
 P_i(t_k) - P_i^{max} (1 - \delta_i(t_k)) &\leq z_i(t_k) |_{i=pur,sale,elz,fc}^{up,down} \\
 z_i(t_k) &\leq P_i(t_k) - P_i^{min} (1 - \delta_i(t_k)) |_{i=pur,sale,elz,fc}^{up,down} \\
 -\delta_i(t_k) + \chi_i(t_k) &\leq 0 |_{i=elz,fc} \\
 -\delta_i(t_{k-1}) + \chi_i(t_k) &\leq 0 |_{i=elz,fc} \\
 \delta_i(t_k) + \delta_i(t_{k-1}) - \chi_i(t_k) &\leq 1 |_{i=elz,fc} \\
 \Delta z_i^{min}(\chi_i(t_k)) &\leq \vartheta_i(t_k) \leq \Delta z_i^{max}(\chi_i(t_k)) |_{i=elz,fc} \\
 \Delta z_i(t_k) - \Delta z_i^{max} (1 - \chi_i(t_k)) &\leq \vartheta_i(t_k) |_{i=elz,fc} \\
 \vartheta_i(t_k) &\leq \Delta z_i(t_k) - \Delta z_i^{min} (1 - \chi_i(t_k)) |_{i=elz,fc} \\
 (P_{grid}(h_i, m_j) - P_{grid}^{sch}(h_i)) &\leq P_{grid}^{max} - P_{grid}^{max} \cdot \delta_{down}(t_k) \\
 (P_{grid}(h_i, m_j) - P_{grid}^{sch}(h_i)) &\geq \epsilon + (-\epsilon) \cdot \delta_{down}(t_k) \\
 -(P_{grid}(h_i, m_j) - P_{grid}^{sch}(h_i)) &\leq P_{grid}^{max} - P_{grid}^{max} \cdot \delta_{up}(t_k) \\
 -(P_{grid}(h_i, m_j) - P_{grid}^{sch}(h_i)) &\geq \epsilon + (-\epsilon) \cdot \delta_{up}(t_k) \\
 \varphi_i - \sum_{s_j=0}^{s_j=\varphi_i} (\lambda_i(t_k - s_j)) &\leq M - M \delta_i |_{i=elz,fc} \\
 \varphi_i - \sum_{s_j=0}^{s_j=\varphi_i} (\lambda_i(t_k - s_j)) &\geq \epsilon + (m - \epsilon) \delta_i |_{i=elz,fc}
 \end{aligned}$$

In order to capture both **continuous/discrete dynamics** and switching between different **operating conditions**, the plant is modelled with the framework of Mixed Logic Dynamic (MLD). The problem is solved using MIQP (Mixed Integer Quadratic Programming).

Some results

- Daily market forecast
- Daily market controller schedule
- Purchase to the grid when price low. Sell when price high
- Constants setpoint to ELZ y FC to minimize degradation
- This will be recomputed.

(zoom)

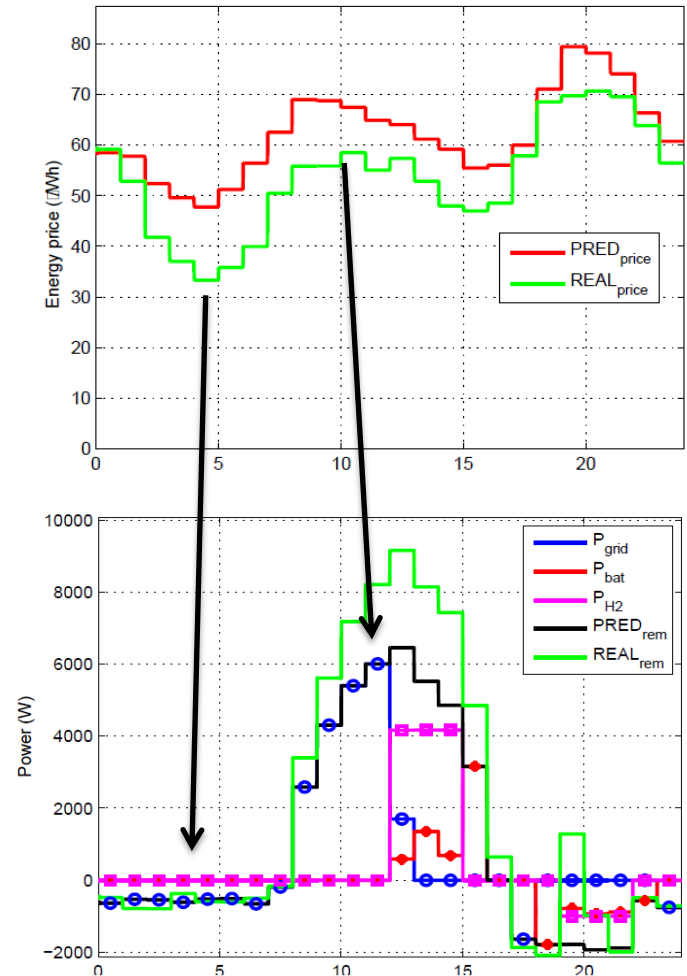
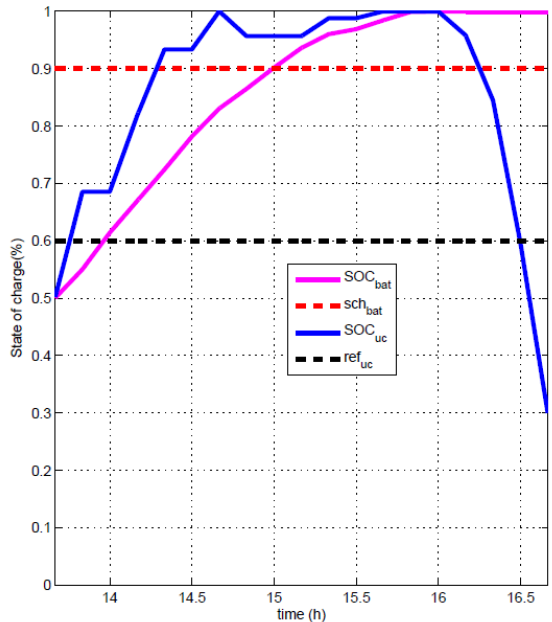

1. Setting the Context
2. Microgrids
3. Experimental testing facility: HyLab
4. Model Predictive Control for μ Grid Power Management
5. Extended control objectives
- 6. Concluding remarks**

- A remarkable lack of applications of advanced Control Strategies → Experimental validation needed
- KPI to assess control methodologies
- MPC showed outstanding features in power management: smooth operation, lower cost, higher lifetime
- Changes in tuning parameters- logical constraints can help fulfil different objectives
- Durability and O&M Cost can be included as control objectives
- Non-dispatchable RES can be converted into dispatchable using the ESS and advanced control. Optimal economic schedule can be achieved
- Open issues for research

- AC microgrids
- Dispatchable microgrids in the pool market
- Contribution of (up-to-now) non-dispatchable RES to frequency regulation (virtual inertia)
- Grids of microgrids (SoS)
- Microgrids for EVs: Distributed storage (electricity and H₂). V2G
- New paradigm of power network

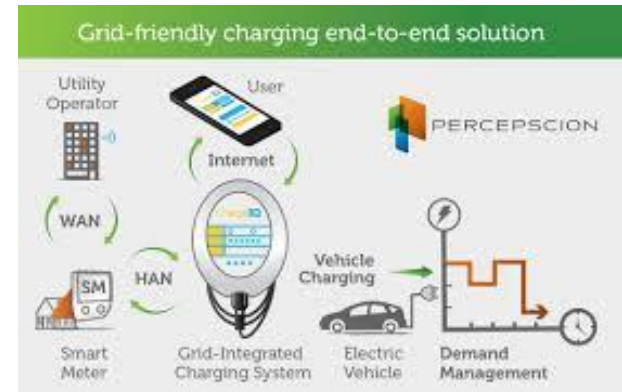



Power Management in Renewable Energy Microgrids with Hybrid Storage

Carlos Bordons
University of Seville, Spain

Thanks to Luis Valverde and Félix García

